

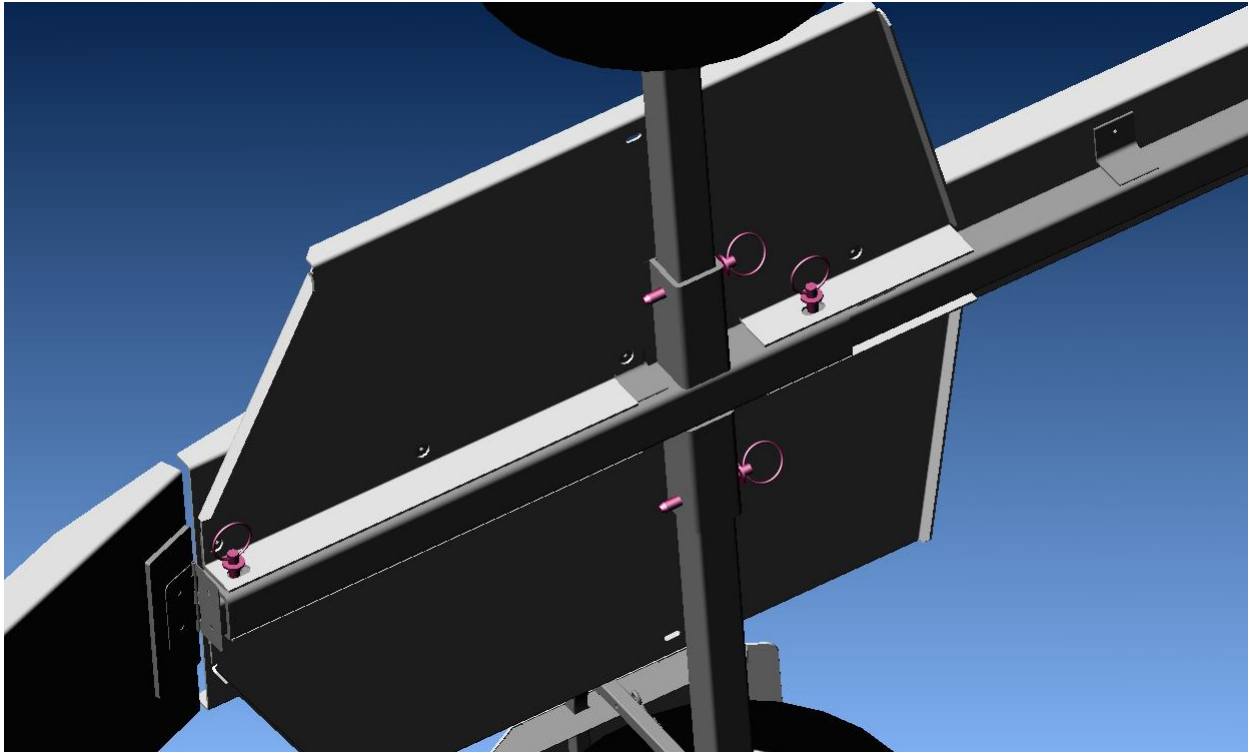

## Running Board Instructions



To attach the Running Boards first place the left and right Running Boards on the correct sides of the trailer. This can be determined by the following features

1. The long side of the running boards face the rear.
2. The long lip with the holes face down. See above image.

The  $\frac{1}{2}$ " pins used to connect the rear to the center and the rear to the ramp are the pins you will use to secure the Running Boards to the trailer.

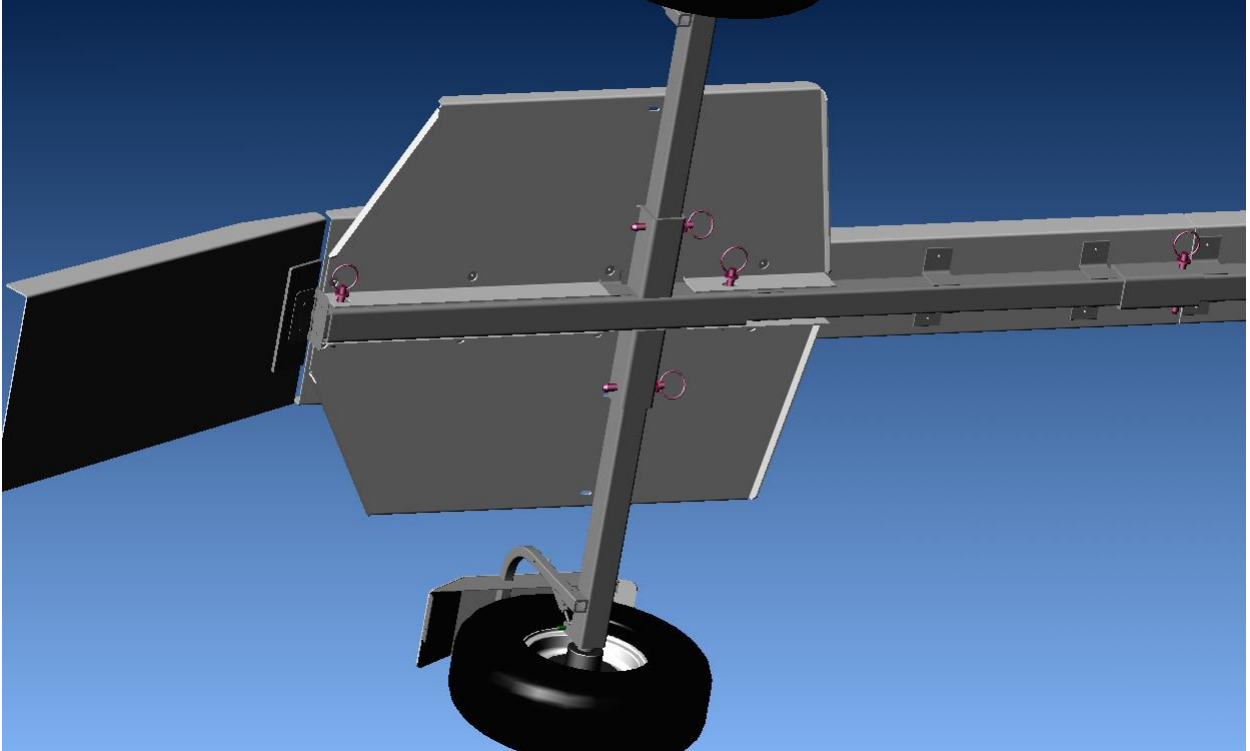
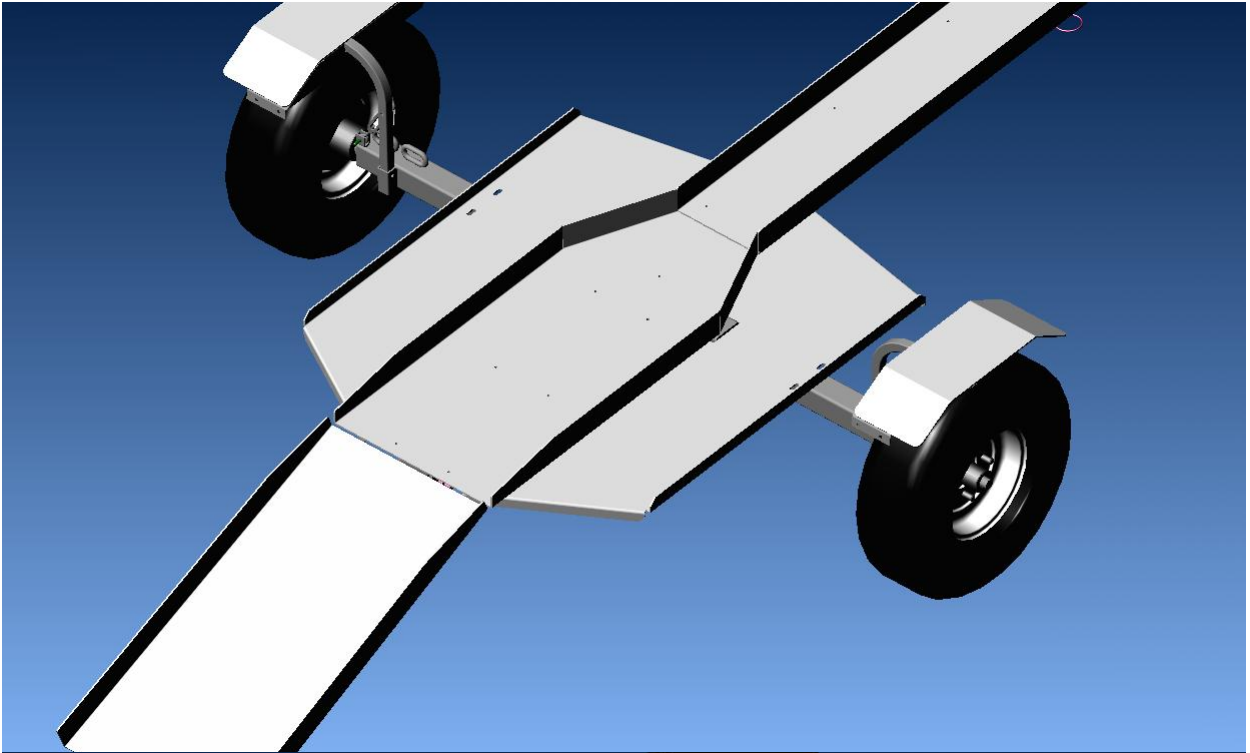



The U-Bolts included in your package are fastened to the running boards thru the holes placed above the axles. We recommend inserting the u-bolts facing down with the hardware on the underside of the trailer to avoid any tripping hazard. The Hardware will go on in the following order (support plate, nut, and wing nut to lock in place).

Once the bike is loaded the pin holding the ramp in will need to be removed to take the ramp off. Then it will need to be re- inserted into the hole to support the running boards during travel.

If you have any questions feel free to call us at 1-800-278-8387